

# Economic Load Dispatch Using Fuzzy Logic Controlled Genetic Algorithms

<sup>1</sup>Vinay Kumar Sharma, <sup>2</sup>Balram Kasniya,

<sup>1</sup>P.G. Research Scholar, <sup>2</sup>Assistant Professor

<sup>1,2</sup>Department of Electrical Engineering

<sup>1</sup>Suresh Gyan Vihar University Jaipur Rajasthan, India

<sup>2</sup>Arya College of Engineering & IT Kukas, Jaipur Rajasthan, India

<sup>1</sup>Email: [vinaykumarsharma44@gmail.com](mailto:vinaykumarsharma44@gmail.com)

<sup>2</sup>Email: [balramchoudhary87@gmail.com](mailto:balramchoudhary87@gmail.com)

**Abstract:** - In this paper, a fuzzy model for power system operation is presented. Uncertainties in loads and generations are modeled as fuzzy numbers. The paper presents the application of a fuzzy logic controlled genetic algorithm (FCGA) to economic dispatch. The authors first propose an improved genetic algorithm with two fuzzy controllers based on some heuristics to adaptively adjust the crossover probability and mutation rate during the optimization process. The implementation of the fuzzy crossover and mutation controllers is described. The proposed FCGA can be applied to a wide range of optimization problems. The validity of the proposed algorithm is illustrated on economic dispatch of a six generator system. Its performance is compared with conventional GA and the Newton-Raphson method. The results are very encouraging. Among the results, one obtains a fuzzy cost value for system operation and possibility distributions for branch power flows and power generations. Some risk analysis is possible, as system robustness and exposure indices can be derived and hedging policies can be investigated.

**Keyword:** fuzzy logic controlled genetic algorithm (FCGA), Economic power dispatch.

## 1 Introduction

Under the ever-strict governmental regulations on environmental protection, the conventional operation at minimum cost can no longer be the only basis for dispatching electric power. Society demands adequate and secure electricity not only at the cheapest possible price, but also at minimum levels of pollution. In particular, since the passage of the Clean Air Act Amendments of 1990 and similar Acts by European and Japanese governments, environmental constraints have

topped the list of utility management concerns [2]. To meet these requirements needs means to reduce SO<sub>2</sub> and NO<sub>x</sub> emission by various methods, such as installing post-combustion cleaning system, switching to fuels with low emission potential and dispatching load with consideration of the environmental issue. Among them, formulation of environmental economic dispatch is preferred in operation of the existing systems because it is easy to implement and requires minimal additional costs. The IEEE current operating problems working group [2] reported potential impacts of clean air regulations on system operations and current practice of some utilities. Including the emissions either in the objective function or treating emissions as additional constraints has been considered in a number of publications. Several methods have been proposed [3-7] since the early work by Gent [3]. [8] Provides a summary of environmental/ economic dispatching algorithms dating back to 1970 using conventional optimization methods. More recently, neural networks [9] and genetic algorithms [10, 11] have been applied to solve this problem. Genetic algorithms (GA) based on the mechanism of natural selection have established themselves as a powerful search and optimization technique. In this technique, the genetic operators such as crossover and mutation have significant impact on its performance. In this paper, two fuzzy controllers based on some heuristics have been designed to adaptively adjust the crossover probability and mutation rate during the optimization process to improve the overall performance. The application of the proposed technique to environmental economic dispatch demonstrates its outstanding performance costs. The IEEE current operating problems working group [2] reported potential impacts of clean air regulations on system operations and

current practice of some utilities. Including the emissions either in the objective function or treating emissions as additional constraints has been considered in a number of publications. Several methods have been proposed [3-7] since the early work by Gent [3]. [8] Provides a summary of environmental/ economic dispatching algorithms dating back to 1970 using conventional optimization methods. More recently, neural networks [9] and genetic algorithms [10, 11] have been applied to solve this problem. Genetic algorithms (GAS) based on the mechanism of natural selection have established themselves as a powerful search and optimization technique. In this technique, the genetic operators such as crossover and mutation have significant impact on its performance. In this paper, two fuzzy controllers based on some heuristics have been designed to adaptively adjust the crossover probability and mutation rate during the optimization process to improve the overall performance. The application of the proposed technique to environmental economic dispatch demonstrates its outstanding performance.

## 2 Fuzzy logic controlled genetic algorithms

The basic GA proceeds as follows [12]:

- (1) Create a population of random individuals, in which each individual represents a possible solution to the problem at hand.
- (2) Evaluate each individual's fitness: its ability to solve the specified problem.
- (3) Select individual population members to be parents.
- (4) Produce children by recombining parent material via crossover and mutation, and add them to the population.
- (5) Evaluate the children's fitness
- (6) Repeat steps 3-5 until a solution with the desired fitness goal is obtained.

Although this basic GA has been applied to some problems [13], its drawbacks prevent the acceptance of the theoretic performances claimed. Thus various techniques [14,15,18] have been studied to improve genetic search. These include using advanced string coding, generating an initial population with some prior knowledge, establishing some better evaluation function, properly choosing parameters,

and using advanced genetic operators. Particularly, as genetic algorithms are distinguished from others by the emphasis on crossover and mutation, more recently much attention and effort has been devoted to improving them. In this respect, two-point, multipoint and uniform crossover, and variable mutation rate have been recently proposed.

In this paper, more advanced genetic operators have been presented which are based on fuzzy logic with the ability to adaptively dynamically adjust the crossover and mutation during the evolution process.

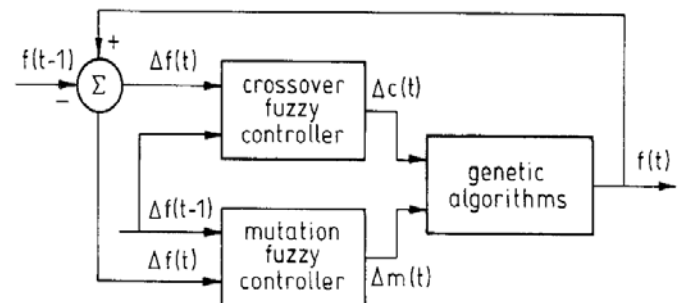

Fig.1 Block Diagram of Proposed Fuzzy Controlled Genetic Algorithm

Fig. 1 presents the block diagram of a fuzzy-controlled genetic algorithm, in which two online fuzzy logic controllers are used to adapt the crossover and mutation. The objective here is to provide a significant improvement in the rate of convergence. The fuzzy controller in Fig. 1 consists of four principal components: fuzzification interface, which converts crisp input data into suitable linguistic values; fuzzy rule base, which consists of a set of linguistic control rules incorporating heuristics that are used for the purpose of achieving a faster rate of convergence; fuzzy inference engine, which is a decision-making logic that employs rules from the fuzzy rule base to infer fuzzy control actions in response to fuzzied inputs; and defuzzification interface, which yields a crisp control action from an inferred fuzzy control action. In the rest of the Section, a detailed description of the design of fuzzy crossover and fuzzy mutation controllers is given

### 2.1 Fuzzy Crossover Controller

The fuzzy crossover controller is implemented to automatically adjust the crossover probability during the optimization process. The heuristic updating principles of the crossover probability is if

the change in average fitness of the populations is greater than zero and keeps the same sign in consecutive generations, the crossover probability should be increased. Otherwise the crossover probability should be decreased.

**2.1.1 Inputs and Output of Fuzzy Crossover Controller:** The inputs to the crossover fuzzy logic controller are changes in fitness at two consecutive steps, i.e.  $\Delta f(t-1)$ ,  $\Delta f(t)$ , and the output of which is change in crossover  $\Delta c(t)$ .

**2.1.2 Membership Functions of  $\Delta f(t-1)$ ,  $\Delta f(t)$ , and  $\Delta c(t)$ :** Membership functions of fuzzy input and output linguistic variables are illustrated in Fig. 2.  $\Delta f(t-1)$ ,  $\Delta f(t)$ , are normalized into the range of  $[-1.0, 1.0]$ , and  $\Delta c(t)$  is normalized into the range of  $[-0.1, 0.1]$  according to their corresponding maximum values.

**2.1.3 Fuzzy Decision Table:** Based on a number of experiments and domain expert opinions, the fuzzy decision table is drawn in Table 1.

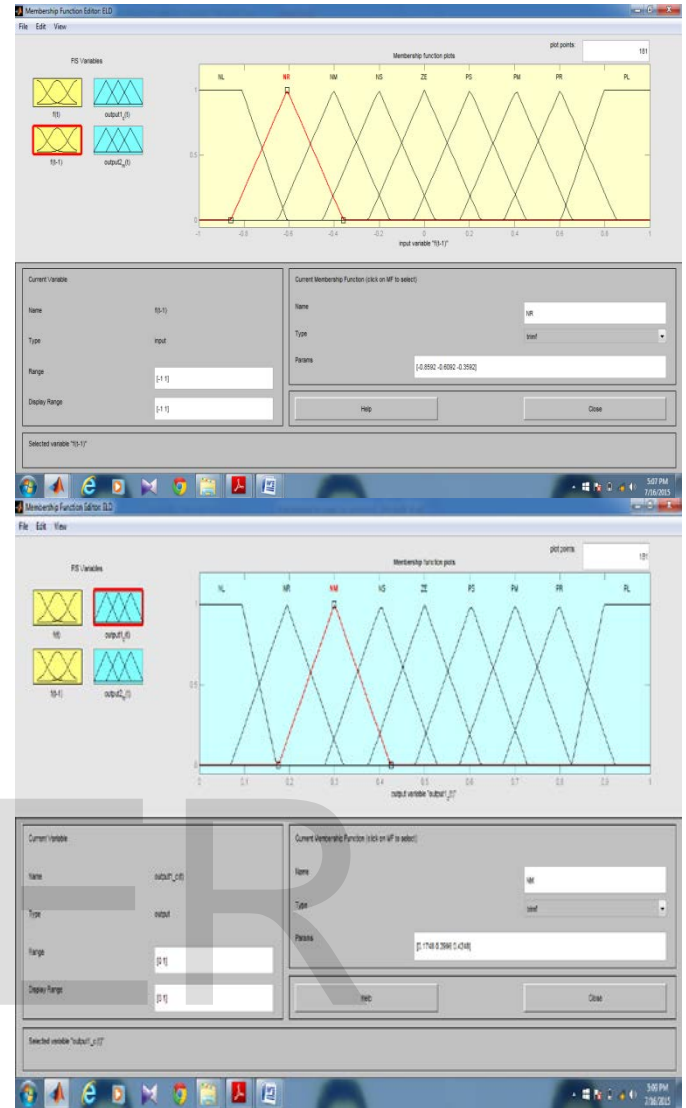
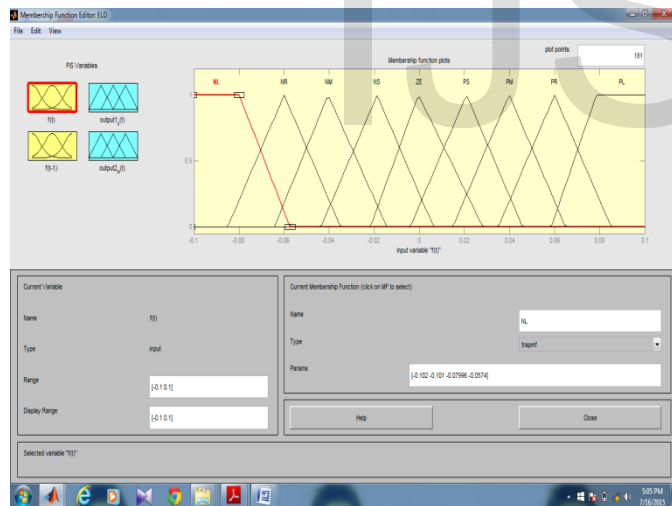

Fig. 2 Membership Function of  $\Delta f(t-1)$ ,  $\Delta f(t)$ ,  $\Delta c(t)$ , NL = negative larger; NR= negative large; NS = negative small; NM = negative medium; ZE = zero; PS = positive small, PM = positive medium; PR = positive large; PL = positive larger

**Table 1: Fuzzy Decision Table for Crossover**

$\Delta c(t)$		$\Delta f(t-1)$								
		NL	NR	NM	NS	ZE	PS	PM	PR	PL
$\Delta f(t)$	NL	NL	NR	NR	NM	NM	NS	NS	ZE	ZE
	NR	NR	NR	NM	NM	NS	NS	ZE	ZE	PS
	NM	NR	NM	NM	NS	NS	ZE	ZE	PS	PS
	NS	NM	NM	NS	NS	ZE	ZE	PS	PS	PM
	ZE	NM	NS	NS	ZE	ZE	PS	PS	PM	PM
	PS	NS	NS	ZE	ZE	PS	PS	PM	PM	PR
	PM	NS	ZE	ZE	PS	PS	PM	PM	PR	PR
	PR	ZE	ZE	PS	PS	PM	PM	PR	PR	PL
	PL	ZE	PS	PS	PM	PM	PR	PR	PL	PL

**Table 2: Lock-up Table for control Action of Crossover**

Z		X								
		-4	-3	-2	-1	0	1	2	3	4
Y	-4	-4	-3	-3	-2	-2	-1	-1	-0	+0
	-3	-3	-3	-2	-2	-1	-1	-0	+0	1
	-2	-3	-2	-2	-1	-1	-0	+0	1	1
	-1	-2	-2	-1	-1	-0	+0	1	1	2
	0	-2	-1	-1	-0	+0	1	1	2	2
	1	-1	-1	-0	+0	1	1	2	2	3
	2	-1	-0	+0	1	1	2	2	3	3
	3	-0	+0	1	1	2	2	3	3	4
	4	-0	1	1	2	2	3	3	4	4

**2.1.4 Look-up table for control actions:** For simplicity, a look-up table for actions of the crossover fuzzy logic controller is set up. First, the quantified levels corresponding to the linguistic values of input and output fuzzy variables of the crossover fuzzy logic controller are designated, which are -4, -3, -2, -1, 0, 1, 2, 3, 4, respectively. Let x label the quantified levels of  $\Delta f(t-1)$ , y label the quantified levels of  $\Delta f(t-1)$ , and z label the quantified levels of  $\Delta c(t)$ . Then the look-up table is formulated as Table 2. In Table 2,  $z = \lfloor \alpha x + (1 - \alpha) y \rfloor$ , where z means a minimum integer which is not greater than  $\alpha x + (1 - \alpha) y$ .  $\alpha$  is an adaptive coefficient which varies with the changes in the fitness of whole populations. It is found that good performances of the crossover fuzzy controller have been achieved when  $\alpha$  equals 0.5. The output of the crossover fuzzy logic controller is formulated in eqn. 1

$$\Delta c(t) = \text{Lock-up Table}[i][j] * 0.02 * \beta \quad (1)$$

where  $i, j \in \{0, 1, 2, 3, 4, 5, 6, 7, 8\}$ , the contents of the look-up table  $[i][j]$  are the values of z in Table 2,  $\beta$  is another adaptive coefficient which is less than 1.0 when the changes in fitness of whole populations are less than 0.02. Therefore the crossover is computed by eqn. 2.

$$\text{crossover}(t) = \text{crossover}(t - 1) + \Delta c(t) \quad (2)$$

## 2.2 Fuzzy Mutation Controller

The mutation operation is determined by the flip function with mutation probability rate, and the mutate bit is randomly performed. The mutation probability rate is automatically modified during the optimization process based on a fuzzy logic controller. The heuristic information for adjusting the mutation probability rate is if the change in average fitness is very small in consecutive generations, then the mutation probability rate should be increased until the average fitness begins to increase in consecutive generations. If the average fitness decreases the mutation probability rate should be decreased. The inputs to the mutation fuzzy controller are the same as those of the crossover fuzzy controller, and the output of which is the change in mutation  $\Delta m(t)$ . The design of the membership function, decision and action tables for the fuzzy mutation controller is similar to these for the fuzzy crossover controller. The proposed fuzzy logic controlled genetic algorithm (FCGA) is then programmed in Turbo C++ on a PC486.

## 3 Environmental/Economic Power Dispatch

There are several ways to take emission into the formulation of economic dispatch. One approach is to include the reduction of emission as an objective. In this Section, as an example, only NO, reduction is considered. The economic emission dispatch can be formulated as

$$\min[F_1, F_2] \quad (3)$$

Subject to

$$P_D + P_L - \sum P_i = 0 \quad (4)$$

$$P_{imin} \leq P_i \leq P_{imax} \quad (5)$$

Where  $F_1$  is the expected fuel cost which is assumed to be approximated by a quadratic function of the generator power output  $P_i$

$$F_1 = \sum(a_i P_i^2 + b_i P_i + c_i) \quad (6)$$

Where  $F_2$  is the expected  $\text{NO}_x$  emission which can be directly related to the cost curve through the emission rate per MBtu

$$F_2 = \sum(d_i P_i^2 + e_i P_i + f_i) \quad (7)$$

where  $P_D$ , is the power demand and  $P_L$ , is the expected transmission loss given by

$$P_L = \sum \sum P_i B_{ij} P_j \quad (8)$$

The multi objective problem (eqn. 3) is converted to a scalar optimization problem with weighted constraints

$$\min\{F = w_1 F_1 + w_2 F_2 + \lambda[P_D + P_L - \sum P_i]\} \quad (9)$$

Where  $w_1$ ,  $w_2$  are weighting coefficients. When  $w_2$  is set to 0, the problem becomes pure economic dispatch or when  $w_1$  is set to 0, the problem becomes pure emission dispatch.  $\lambda$  is the Lagrangian operator. When fuel cost coefficients, emission coefficients and load demand are considered as random variables, the basic economic emission dispatch can be extended as a stochastic problem which is detailed in [7]. The stochastic economic emission provides the facility to consider the inaccuracies and uncertainties in the economic dispatch procedure.

#### 4 Tests and results

As Two test examples are presented to illustrate the proposed FCGA. The first is a pure economic dispatch problem. Comparison between GA and

FCGA is reported for this example. The second one is an emission economic dispatch. Results are compared with a stochastic method.

#### 4.1 Test 1: economic dispatch

The first test is carried out on pure economic dispatch of a six generator system. The data employed in this paper are obtained from [17]. The fuel cost function of each unit is a quadratic function of the generator real power output, and the output limits are given as follows:

$$\begin{aligned} F_1 &= 0.00156P_1^2 + 7.92P_1 + 561.0 & 100 < P_1 < 600 \\ F_2 &= 0.00194P_2^2 + 7.85P_2 + 310.0 & 100 < P_2 < 400 \\ F_3 &= 0.00482P_3^2 + 7.97P_3 + 78.0 & 50 < P_3 < 200 \\ F_4 &= 0.00139P_4^2 + 7.06P_4 + 500.0 & 140 < P_4 < 590 \\ F_5 &= 0.00184P_5^2 + 7.46P_5 + 295.0 & 110 < P_5 < 440 \\ F_6 &= 0.00184P_6^2 + 7.46P_6 + 295.0 & 110 < P_6 < 440 \end{aligned}$$

The load demand is assumed to be 1800, 1200 and 800MW. For simplicity, transmission losses are ignored in the test. For solving the environmental economic dispatch problem, the fitness function is chosen to be

$$f = K/F \quad (10)$$

Where  $F$  is the value of the objective function defined by eqn. 9 and  $K$  is a large constant.  $K$  is used to amplify the value of  $1/F$ , which is usually very small, such that the fitness values of the strings are in a wider range for the selection process. The parameters used in conventional GA and FCGA are: population size = 100; sub chromosome length (i.e. for each unit) = 10; optimized parameters = 6; chromosome length = 60; initial crossover rate = 0.5; initial mutation rate = 0.01; Desired generations = 100. The economic dispatch results obtained by the conventional genetic algorithms (CGAs) and the fuzzy

**Table 3: Economic dispatch results by CGAs and FCGAs**

Method	Load (MW)	Unit 1 (MW)	Unit 2 (MW)	Unit 3 (MW)	Unit 4 (MW)	Unit 5 (MW)	Unit 6 (MW)	Total Cost (\$)	Computing Time (s)
--------	-----------	-------------	-------------	-------------	-------------	-------------	-------------	-----------------	--------------------

CGAs	800	109.17	104.08	52.04	305.05	114.83	114.83	8232.89	14.16
FCGAs	800	104.89	102.87	51.74	314.18	113.16	113.16	8231.03	05.62
CGAs	1200	142.55	117.80	58.90	515.20	182.78	182.78	11493.74	17.83
FCGAs	1200	131.50	129.05	52.08	494.08	200.61	200.61	11480.03	7.43
CGAs	1800	222.42	190.73	95.36	555.63	367.92	367.92	16589.05	19.66
FCGAs	1800	250.49	215.43	109.92	572.84	325.66	325.66	16585.85	10.44

**4: Pure economic and pure emission dispatch results by FCGAs**

	Pure economic dispatch			Pure economic dispatch		
Load	500	700	900	500	700	900
Fuel Cost (\$/h)	28150.80	38384.09	49655.40	28756.71	39455.00	53299.64
Emission (kg/h)	314.53	543.48	877.61	286.59	516.55	785.64
Power loss (MW)	18.86	36.15	58.58	24.61	42.44	65.00
Computing time (s)	34.18	74.65	122.41	6.67	15.55	39.12
Unit 1	49.47	72.14	101.11	81.08	120.16	133.31
Unit 2	29.40	50.02	67.64	13.93	21.36	110.00
Unit 3	35.31	46.47	50.39	66.37	62.09	100.38
Unit 4	70.42	99.33	158.80	85.59	128.05	119.27
Unit 5	199.03	264.60	324.08	141.70	209.65	250.79
Unit 6	135.22	203.58	256.56	135.93	201.12	251.25
Total capacity(MW)	518.86	736.14	958.57	524.60	742.44	964.99

**Table 5: Economic emission dispatch by FCGAs and Newton-Raphson method**

FGAs	Newton Raphson Method
------	-----------------------

Load	500	700	900	500	700	900
Fuel Cost (\$/h)	28231.06	38408.82	49674.28	28550.15	39070.74	50807.24
Emission (kg/h)	304.90	527.46	850.29	312.513	528.447	864.060
Power loss (MW)	17.41	32.85	54.92	17.162	34.927	54.498
Computing time (s)	50.22	124.66	176.41	-	-	-
Unit 1	65.23	80.16	111.40	59.873	85.924	122.004
Unit 2	24.29	53.71	69.33	39.651	60.963	86.523
Unit 3	40.44	40.93	59.43	35.000	53.909	59.947
Unit 4	74.22	116.23	143.26	72.397	107.124	140.959
Unit 5	187.75	251.20	319.40	185.241	250.503	325.000
Unit 6	125.48	190.62	252.11	125.000	176.504	220.063
Total capacity(MW)	517.41	732.85	954.92	517.162	734.927	954.498

Controlled genetic algorithm (FCGA) is given in Table 3. Figs. 3a and 3b, respectively, show the cost curves of FCGAs and CGAs when load demand is assumed to be 1800MW during the optimization process. The outstanding performances of FCGA, such as the reduction of both the cost and the computation time, can be clearly seen. Furthermore, the cost curve of Fig. 3b is oscillating from one generation to another. This is mainly because the crossover rate and mutation rate have been kept constant in CGAs. This causes problems to set criteria to stop the search for an optimal solution. On the other hand, the cost curve of the proposed FCGA indicates the solution is improved during each generation.

#### 4.2 Tests 2: Economic Emission Dispatch

The second example is the six-generator system from [7], which details the fuel cost and NO<sub>x</sub> emission equations, the average expected transmission loss coefficients, and the operating limits of the generators. The type of the fuel burned is assumed to be fixed. The parameters used in FCGA are: population size = 200; sub chromosome length (i.e. for each unit) = 10; optimized parameters = 6; chromosome length = 60; initial crossover rate = 0.6; initial mutation rate = 0.03; desired generations = 200. Table 4 presents the results obtained by the FCGA for pure economic and pure emission dispatch. Table 5 presents the results obtained by the proposed FCGA method and the Newton-Raphson method (case 1 of Tables 5

and 6 in [7]). From Tables 4 and 5, it is clear that pure economic dispatch produces a minimum cost dispatch and the emission is higher. In the pure emission dispatch, emission is minimum and the cost is higher. The economic emission dispatch products a suboptimal solution to both economic and emission objectives. When comparing FCGA's results with the Newton-Raphson method in Table 5, the reduction of fuel cost and emission is very clear in all the three load demands by the FCGA method, while constraint are satisfied and transmission losses are kept almost the same.

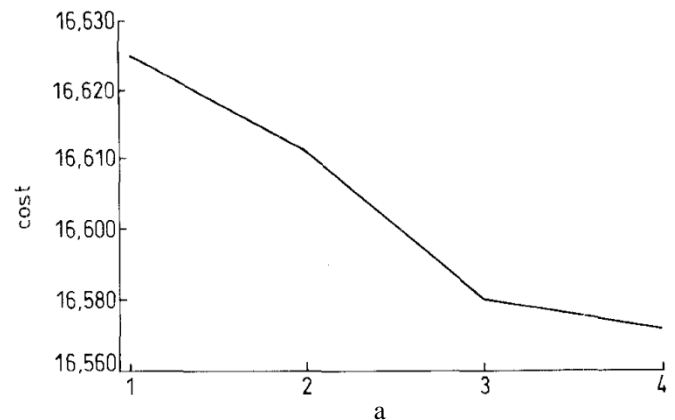

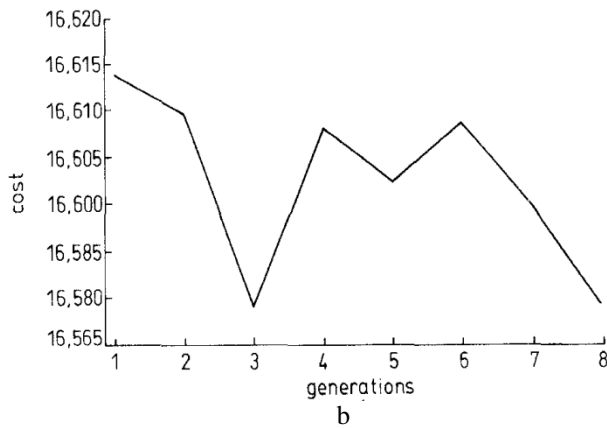

Fig. 3 Cost curve for FCGAs and CGAs  
 a FCGAs  
 b CGAs

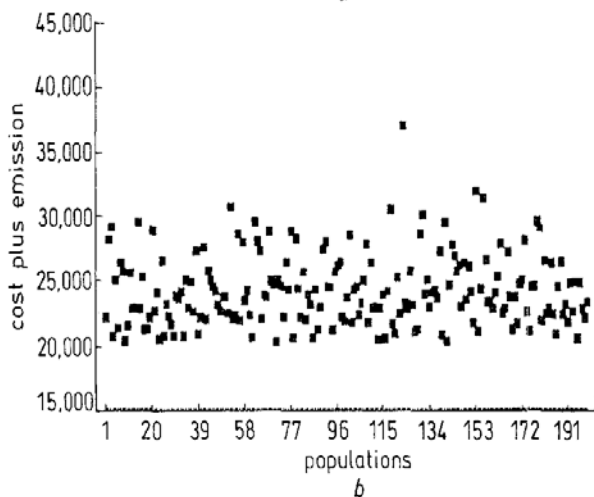
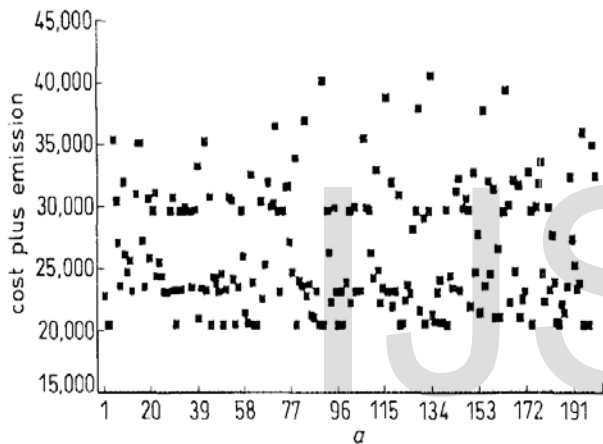

Fig. 4 Initial and Tenth Population  
 a Initial 200 Population  
 b Tenth Population

To appreciate the evolution process of the FCGAs, Fig. 4*a* illustrates the initial 200 populations which are generated randomly. Fig. 4 gives the population of the tenth generation. It can be seen that the

population is grouping towards the optimal point. However, there are some points scattering in the whole space. These points reflect the effect of mutation which has the ability of avoiding premature convergence or sticking to a local minimum. Fig. 5 illustrates the best and average fitness curves generated by FCGA when load demand is assumed to be 900MW.

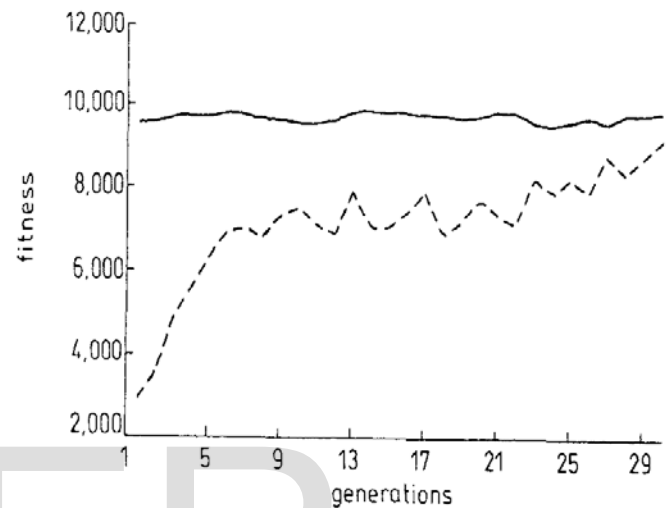

Fig. 5 Fitness Curve of FCGA  
 — best  
 - - - average

### 5 Conclusions

Environmental concern is an important issue in the operation of modern power systems. This paper has proposed fuzzy controlled genetic algorithms for environmental/ economic dispatch. Two fuzzy controllers have been designed to adaptively adjust the crossover probability and mutation rate during the optimization process based on some heuristics. The implementation of fuzzy crossover and mutation controllers has been described. The proposed algorithm has been tested on a six-generator economic emission load dispatch problem. Compared with conventional GA and the Newton- Raphson method, the results reported have demonstrated the improved performances by the proposed algorithm. It is worth pointing out that the proposed FCGA can be applied to a wide range of optimization problems.

### 6 References

[1] .H.Song, G.S. Wang, and PY.Wang, "Environmental /economic dispatch using



- fuzzy logic controlled genetic algorithms” IEE Proc.-Genre Trans. Diatribe. vol. 144. No. 4, July 1997.
- [2] IEEE Current Operating Problems Working Group: “Potential impacts of clean air regulations on system operations”, IEEE Trans **PWRS-10**, pp. 647-653, 1995.
- [3] GENT, M.R., LAMONT, and J.W.: “Minimum-emission dispatch”, IEEE Trans., **PAS-90**, pp. 2650-2660, 1971.
- [4] EL-KEIB. A.A., MA. H And HART, J.L.: “Environmentally constrained economic dispatch using the lagrangian relaxation method”, IEEE Trans., **PWRS-9**, pp. 1723-1729
- [5] NARAYAN, S.R., and ADELMAN. S.T.: “Operating strategies under emission constraints”, IEEE Trans., **PWRS-10**, pp. 1585-1591, 1995.
- [6] RAMANATHAN, R “Short-term energy and emission trading analysis” IEEE trans., **PWRS-10**, pp. 1118-1124, 1995.
- [7] DHILLON, J.S., PARTI S.C. and KOTHARI, D.P. “Stochastic economic emission load dispatch”, Electric Power syst. Res., pp. 179-186, 1993.
- [8] TALAQ, J.H., EL-HARWARY, F., and EL-HARWARY, M.E.: “A summary of environmental/economic dispatch algorithms”, IEEE Trans., **PWRS-9**, (3) pp. 1508-1516, 1994,
- [9] KING, T.D., EL-HAKWARY. M.E. and EL-HARWARY, F.: “Optimal environmental dispatching of electric power systems via an improved Hopfield neural network model”, IEEE Trans., **PWRS-10**, (3) pp. 1559 1565, 1995,
- [10] SONG. Y.H., LI, F., MORGAN, R. and WILLIAMS, D.: “Environmentally constrained electric power dispatch with genetic algorithms”. Proc. TEEE IECE, Perth. 1995.
- [11] SWARUP, K.S., YOSHIMI, M., ZUI, Y.; and NACAI, N.: 14 Proc., ISAP’94, pp. 707-714, 1994.
- [12] COLDBERG, D.E.: “Genetic algorithms in search optimization and machine learning”(Addison Wesley, 1989)
- [13] LI, F., SONG. Y.H., MORGAN, R., and CHENG, D.T.Y.: “Genetic algorithms in power system optimization”, Proc. of conference on Adaptive computing, pp. 77-83, 1994.
- [14] DAVIS, L.: “Handbook of genetic algorithms” (Van Nostrand Reinhold. 1991)
- [15] Proc. of the international conference on Genetic algorithms, 3<sup>rd</sup> (1989), 4th (1991), 5th (1993), USA
- [16] AJJARAPU, V., and ALBANNA, Z.: “Application of genetic algorithms to optimal capacitor placement”. Proc. of first conf. on Neural networks in power systems, pp. 251-255, 1991.
- [17] SONG, Y.H., LI, F.MORGAN. R. and CHENG. D.T.Y.: “Effective implementation of algorithms on power economic dispatch”. Proc. IPEC’95, pp. 268-274, 1995.
- [18] SHEBLE. G.B. and BRITTIG, K.: “Refined genetic algorithm economic dispatch example”. IEEE Tran., **PWRS-10**. (1) pp. 117-123. ., 1995.